



# Modular Cooking Range Line 900XP 2 Drawer Refrigerated Base (60Hz)

ITEM # \_\_\_\_\_

MODEL # \_\_\_\_\_

NAME # \_\_\_\_\_

SIS # \_\_\_\_\_

AIA # \_\_\_\_\_

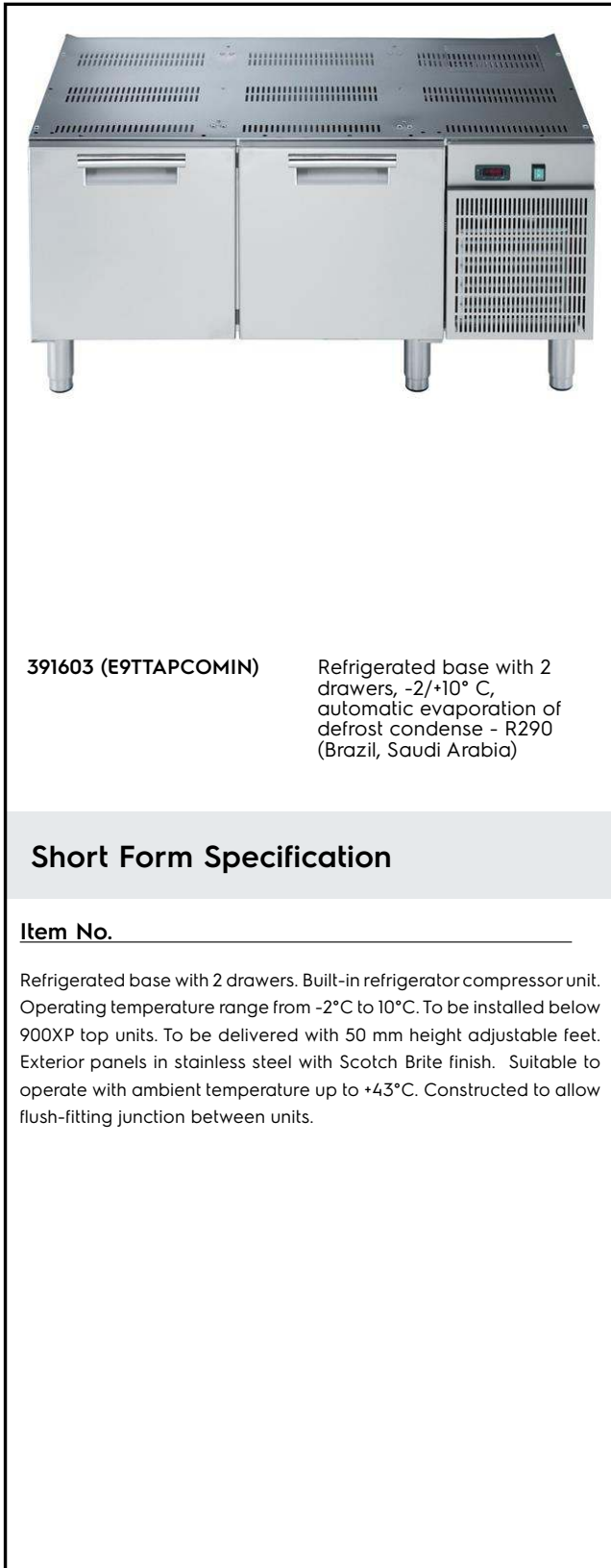

391603 (E9TTAPCOMIN)

Refrigerated base with 2 drawers, -2/+10° C, automatic evaporation of defrost condense - R290 (Brazil, Saudi Arabia)

### Short Form Specification

Item No. \_\_\_\_\_

Refrigerated base with 2 drawers. Built-in refrigerator compressor unit. Operating temperature range from -2°C to 10°C. To be installed below 900XP top units. To be delivered with 50 mm height adjustable feet. Exterior panels in stainless steel with Scotch Brite finish. Suitable to operate with ambient temperature up to +43°C. Constructed to allow flush-fitting junction between units.

### Main Features

- Unit can be easily installed below other 900 line top models.
- Adjustable temperature range from -2 °C to +10 °C to suit meat, fish and dairy storage requirements.
- Forced air circulation for rapid cooling and an even temperature distribution.
- Designed for modular installation into the cooking block.
- Anti-tilt runners accept GN 1/1 containers.

### Construction

- Constructed in Stainless steel with Scotch Brite finish to meet the highest hygiene standards.
- Built-in compressor to suit operating conditions.
- Access to all components from the front.
- Unit delivered with 150 mm height adjustable feet in Stainless steel. Feet can be extended up to 250 mm.

### Sustainability



- CFC and HCFC free (highly ecological refrigerant type: R290).

### Optional Accessories

- Flanged feet kit PNC 206136
- Frontal kicking strip for concrete installation, 1200mm PNC 206151
- Frontal kicking strip, 1200mm (not for refr-freezer base) PNC 206178
- Rear paneling - 1200mm (700/900) PNC 206376
- Kit 3 base support for wheels PNC 206430
- Kit 6 wheels - 3 swivelling with brake PNC 206432

APPROVAL: \_\_\_\_\_



Experience the Excellence  
www.electroluxprofessional.com

Front

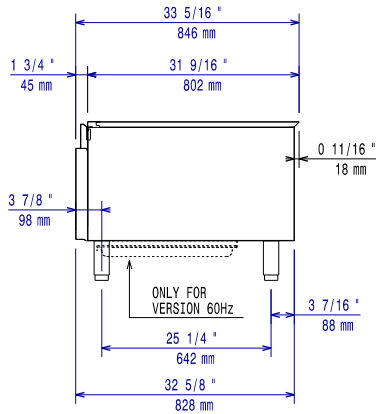

Side

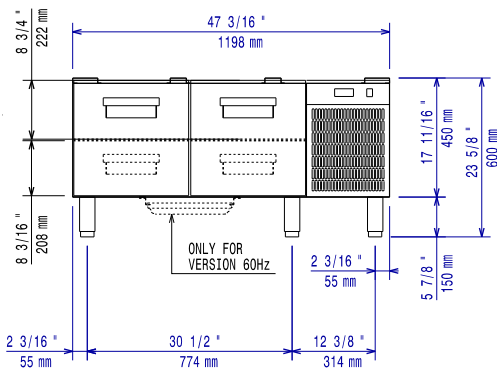

D = Drain  
 EI = Electrical inlet (power)

Top

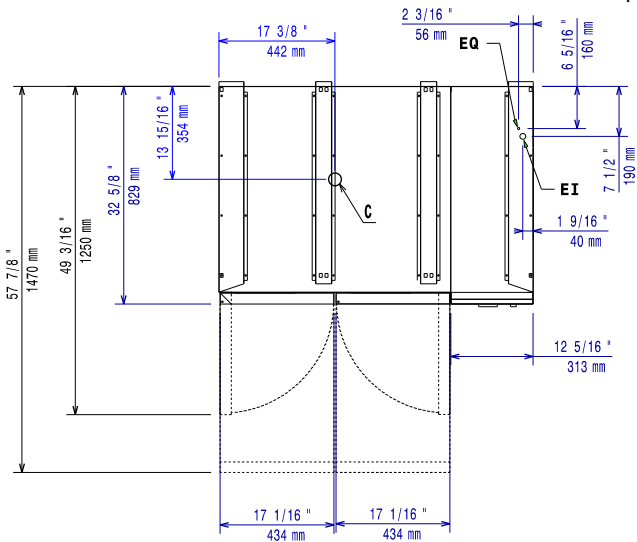

## Electric

Supply voltage:	391603 (E9TTAPCOMIN)	220-230 V/1N ph/60 Hz
Electrical power max.:		0.4 kW
Total Watts:		0.4

## Key Information:

Gross capacity:	140 lt
External dimensions, Width:	1200 mm
External dimensions, Depth:	830 mm
External dimensions, Height:	600 mm
Net weight:	114 kg
Shipping weight:	121 kg
Shipping height:	820 mm
Shipping width:	1060 mm
Shipping depth:	1300 mm
Shipping volume:	1.13 m <sup>3</sup>

## Refrigeration Data

Compressor power:

## Sustainability

Refrigerant type:	R290
Refrigerant weight:	85 g